



VISION GROUP
Shenzhen Center Power
Tech.Co.Ltd.,

6FM80D-X

12V 75.6Ah(20hr)

Overview

The rechargeable batteries are lead-lead dioxide systems. The dilute sulfuric acid electrolyte is absorbed by separators and plates and thus immobilized. Should the battery be accidentally overcharged producing hydrogen and oxygen, special oneway valves allow the gases to escape thus avoiding excessive pressure build-up. Otherwise, the battery is completely sealed and is, therefore, maintenance-free, leak proof and usable in any position.



Battery Construction

Component	Positive plate	Negative plate	Container	Cover	Safety valve	Terminal	Separator	Electrolyte
Raw material	Lead dioxide	Lead	ABS	ABS	Rubber	Copper	Fiberglass	Sulfuric acid

General Features

- Absorbent Glass Mat (AGM) technology for efficient gas recombination of up to 99% and freedom from electrolyte maintenance or water adding.
- Not restricted for air transport-complies with IATA/ICAO Special Provision A67.
- UL-recognized component.
- Can be mounted in any orientation.
- Computer designed lead, calcium tin alloy grid for high power density.
- Long service life, float or cyclic applications.
- Maintenance-free operation.
- Low self discharge.
- Case and cover available in both standard and flame retardant ABS.

Battery Specification

Performance Characteristics	
Nominal Voltage	12V
Number of cell	6
Design Life	10 years
Nominal Capacity 77°F(25°C)	
20 hour rate (3.78A, 10.8V)	75.6Ah
10 hour rate (7.20A, 10.8V)	72.0Ah
5 hour rate (12.9A, 10.5V)	64.5Ah
1 hour rate (47.6A, 9.6V)	47.6Ah
Internal Resistance	
Fully Charged battery 77°F(25°C)	5.5 mOhms
Self-Discharge	
3% of capacity declined per month at 20°C(average)	
Operating Temperature Range	
Discharge	-20-60°C
Charge	-10-60°C
Storage	-20-60°C
Max. Discharge Current 77°F(25°C)	750A(5s)
Short Circuit Current	1900A
Charge Methods: Constant Voltage Charge 77°F(25°C)	
Cycle use	2.30-2.35VPC
Maximum charging current	24.0A
Temperature compensation	-30mV/°C
Standby use	2.23-2.27VPC
Temperature compensation	-20mV/°C

Dimensions and Weight

Length(mm / inch)	350 / 13.78
Width(mm / inch)	167 / 6.57
Height(mm / inch)	179 / 7.05
Total Height(mm / inch)	179 / 7.05
Approx. Weight(Kg / lbs)	22.5 / 49.6

* Weight deviation: ± 5%

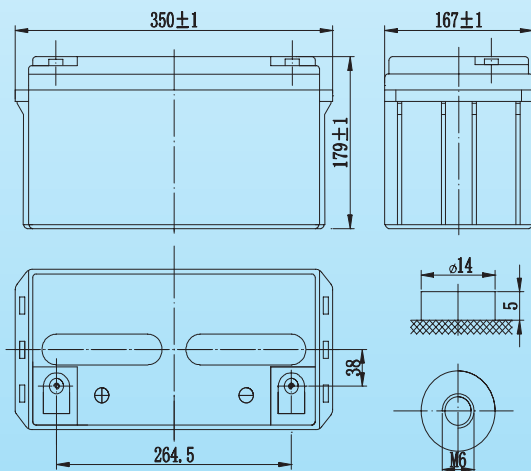

Discharge Constant Current (Amperes at 77°F25°C)

End Point								
Volts/Cell	10min	15min	30min	1h	3h	5h	10h	20h
1.60V	163	130	76.7	47.6	20.2	13.5	7.38	3.85
1.65V	154	120	72.9	45.8	20.0	13.3	7.34	3.84
1.70V	145	115	70.5	44.2	19.7	13.1	7.29	3.82
1.75V	138	110	68.1	41.8	19.4	12.9	7.25	3.80
1.80V	129	103	65.9	41.1	18.4	12.6	7.20	3.78

Discharge Constant Power (Watts at 77°F25°C)

End Point								
Volts/Cell	10min	15min	30min	45min	1h	2h	3h	5h
1.60V	280	225	145	109	87.4	54.0	37.8	25.0
1.65V	268	218	138	108	86.7	53.5	36.5	24.5
1.70V	259	215	133	103	83.2	52.6	35.9	24.2
1.75V	248	203	131	101	81.8	51.6	35.4	24.0
1.80V	238	190	128	98	78.5	50.7	34.6	23.6

(Note)The above characteristics data are average values obtained within three charge/discharge cycles not the minimum values.All data shall be changed without notice, Vision reserves the right to explain and update the information contained hereinto.



VISION GROUP
Shenzhen Center Power
Tech.Co.Ltd.,

6FM80D-X

12V 75.6Ah(20hr)

